

ROUTE	STATE	DISTRICT	SHEET NO.
	MO		
JOB NO.			
CONTRACT ID.			
PROJECT NO.			
COUNTY			DATE

"THIS MEDIA SHOULD NOT BE CONSIDERED A CERTIFIED DOCUMENT."

IF A SEAL IS PRESENT ON THIS SHEET IT HAS BEEN ELECTRONICALLY SEALED AND DATED.

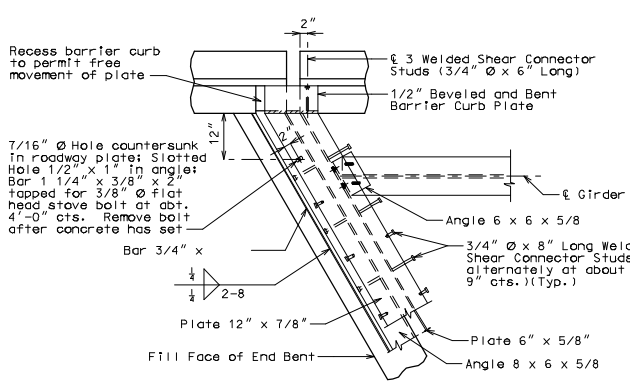

PART PLAN

Note: Concrete vent holes not shown for clarity.

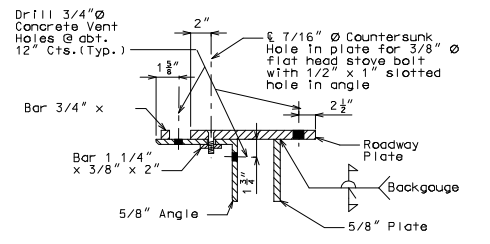

PART SECTION (TYPICAL)

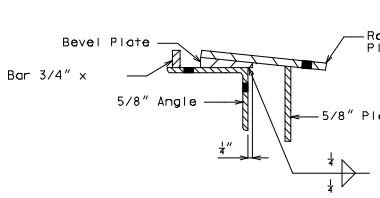
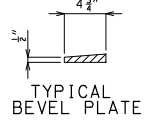

PART SECTION THRU BEVEL PLATE

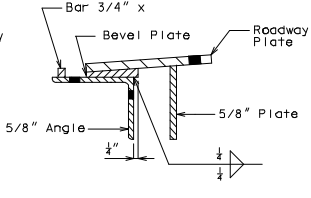

PART SECTION THRU BEVEL PLATE

Note: Bevel plates shall be used at end bents when the grade of the slab at expansion device is 3% or more.

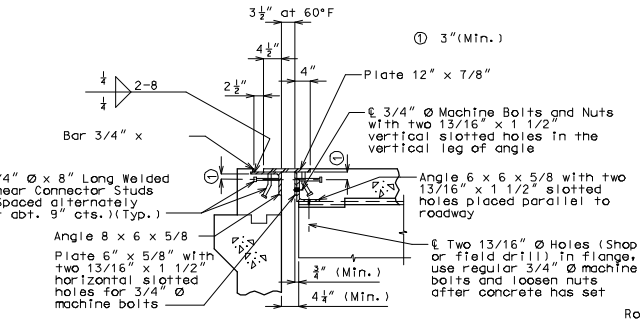

PART SECTION AT END BENT

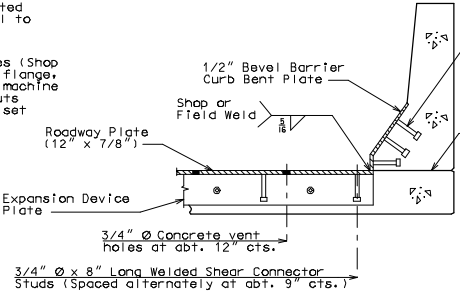

PART SECTION A-A

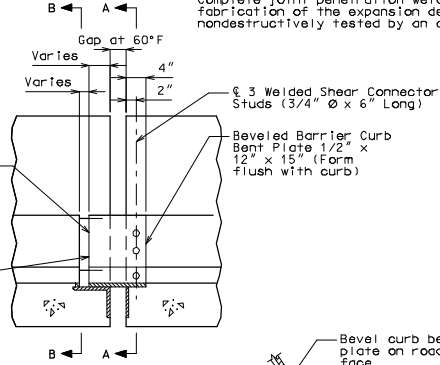

ELEVATION OF BARRIER CURB

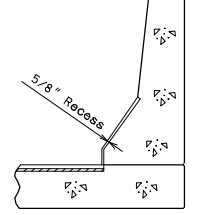

PART SECTION B-B

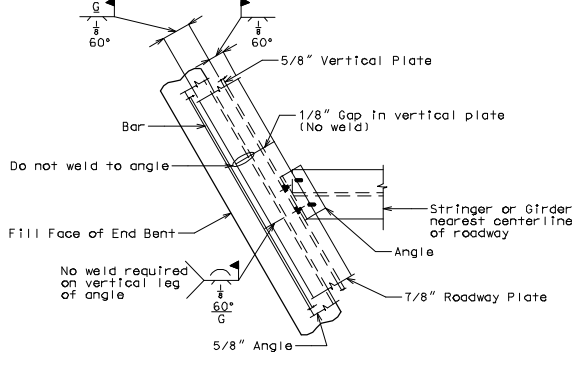

PERMISSIBLE FIELD SPLICE AT END BENT

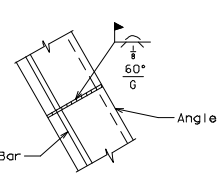

PART PLAN OF ANGLE AND BAR

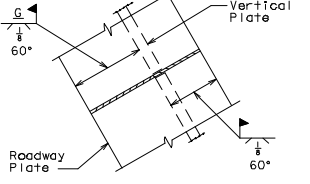

PART PLAN ROADWAY PLATE AND VERTICAL PLATE

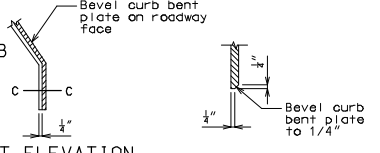

SECTION C-C

PART ELEVATION AT END OF BEVELED CURB BENT PLATE

DETAILS OF FLAT PLATE EXPANSION DEVICE AT END BENT NO.

Detailed Checked

Note: This drawing is not to scale. Follow dimensions.

Sheet No. of

FPE 7