

ROUTE	STATE	DISTRICT	SHEET NO.
	MO		
JOB NO.			
CONTRACT ID			
PROJECT NO.			
COUNTY			DATE

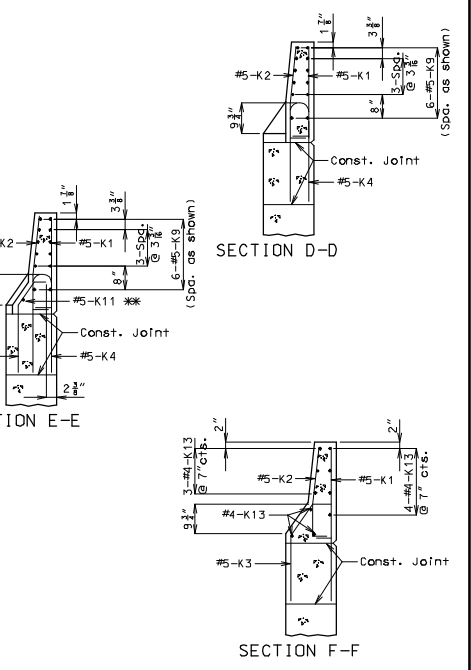
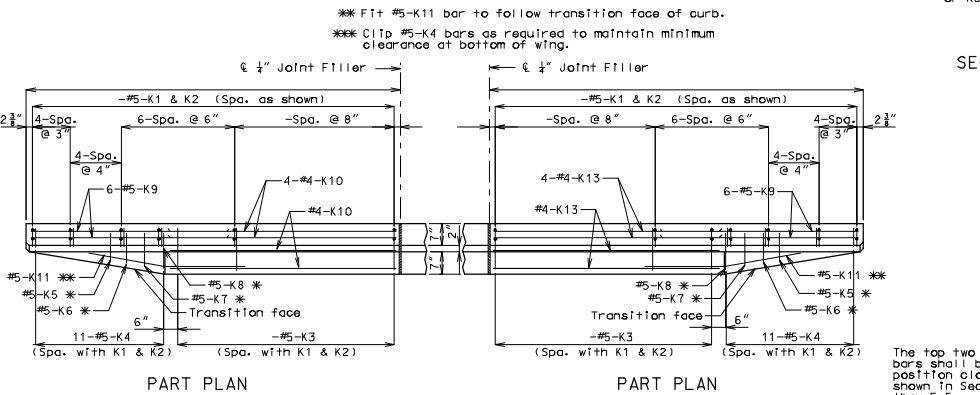
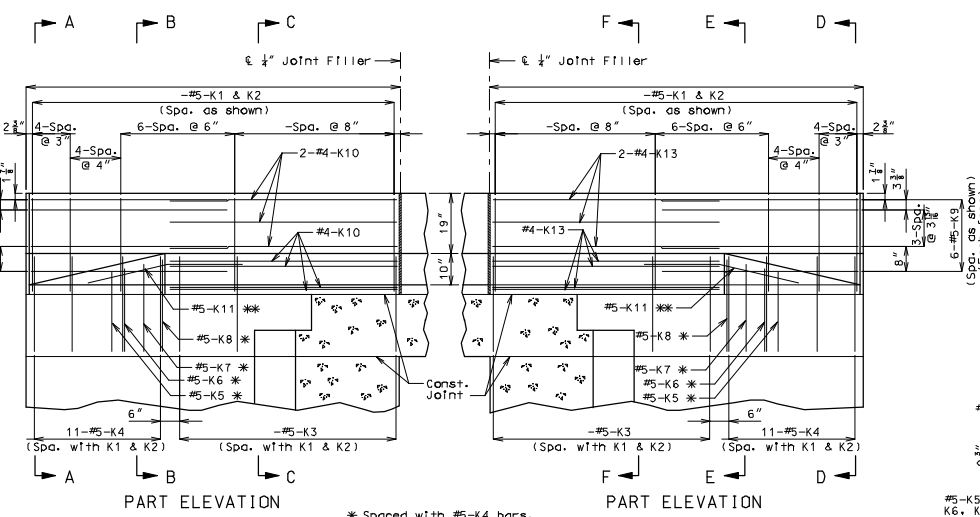
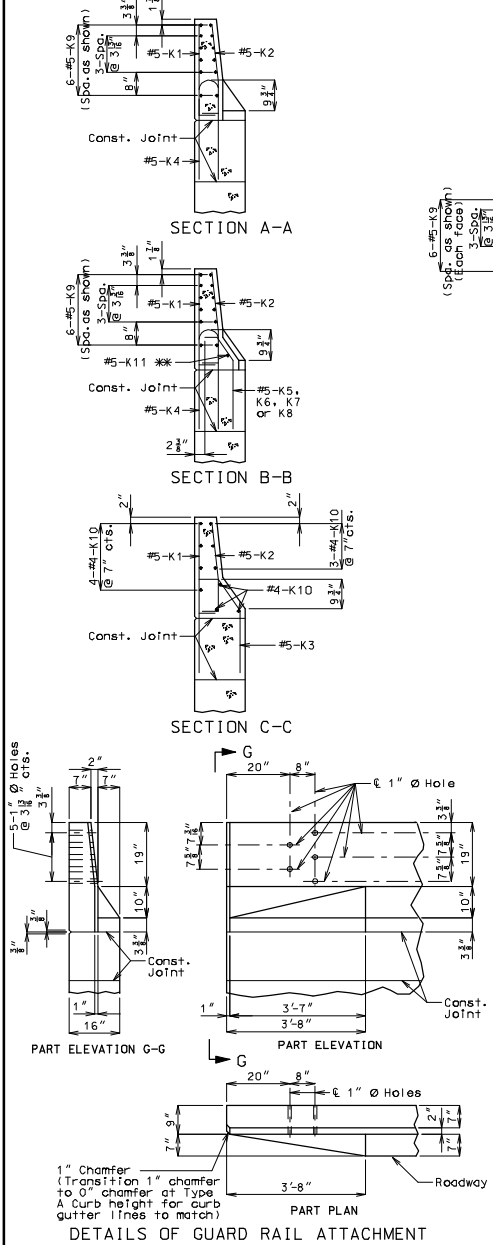

Note to Detailer:
 For #5-K3 & K4 Bars, use Shape 11 or create shape as necessary when development length requires hook.

NOTES: Use a minimum lap of 2'-0" between K9 and K10 or K13 bars.
 Concrete traffic barrier delineators shall be placed on top of the safety barrier curb as shown on Missouri Standard Plans 617.10 and in accordance with Sec 617. Concrete traffic barrier delineators will be considered completely covered by the contract unit price for "Safety Barrier Curb".

DETAILS OF SAFETY BARRIER CURB AT END BENTS
 (Left barrier curb shown: right barrier curb similar)

