

ROUTE	STATE	DISTRICT	SHEET NO.
	MO		
JOB NO.			
CONTRACT ID.			
PROJECT NO.			
COUNTY	DATE		

"THIS MEDIA SHOULD NOT BE CONSIDERED A CERTIFIED DOCUMENT."

NOTE TO DETAILER: BRIDGE SUBSTRUCTURE INFORMATION WILL VARY PER PROJECT

NOTE TO DETAILER:
Check with Project Manager to determine if permanent, temporary or no steel casing will be used.

NOTE TO DETAILER:
Number of pipes (equally spaced) for sonic logging test

	Diameter ≤ 2.5 ft (750 mm)	2 pipes
2.5 ft (750 mm) <	Diameter ≤ 3.5 ft (1050 mm)	3 pipes
3.5 ft (1050 mm) <	Diameter ≤ 5.0 ft (1500 mm)	4 pipes
5.0 ft (1500 mm) <	Diameter ≤ 8.0 ft (2400 mm)	6 pipes
8.0 ft (2400 mm) <	Diameter	8 pipes

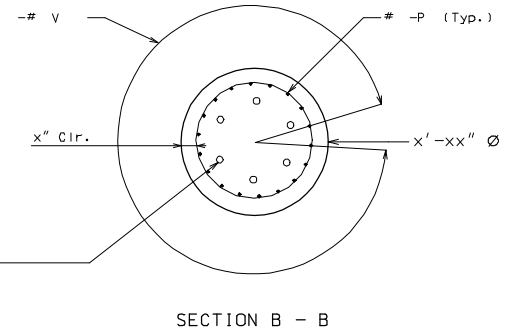
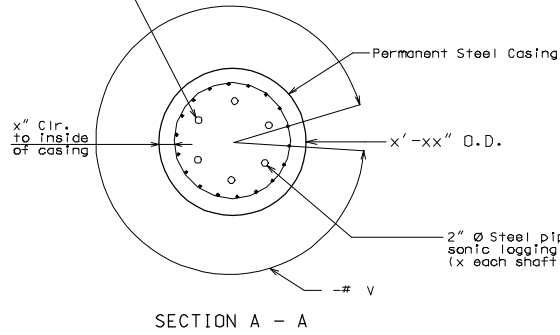
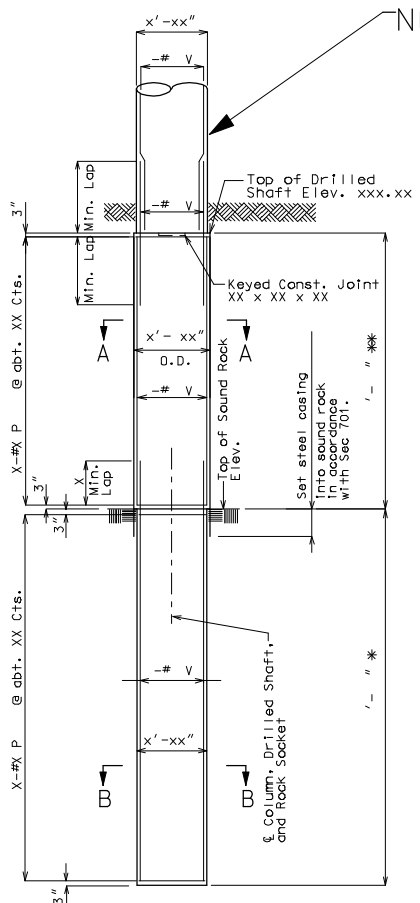

ELEVATION OF DRILLED SHAFTS AND ROCK SOCKETS

* Pay Items Rock Socket (' - " diameter)
* Pay Items Drilled Shaft (' - " diameter)

Substructure Quantity Table for Bent No.	
Item	Quantity
Class 1 Excavation	cu. yard
Class 2 Excavation	cu. yard
Drilled Shafts (X ft. X In. Diameter)	linear foot
Rock Sockets (X ft. X In. Diameter)	linear foot
Supplementary Television Camera Inspection	each
Foundation Inspection Holes	linear foot
Concrete Coring	linear foot
Sonic Logging Testing	each
Class B Concrete (Substructure)	cu. yard
Reinforcing Steel (Bridges)	pounds

These quantities are included in the estimated quantities table on sheet no. . .

NOTE:

An additional 4 feet has been added to V-bar lengths for possible change in drilled shaft or rock socket depth. This excess length shall be cut-off or included in the reinforcement lap if not required.

Concrete coring shall be performed on of the drilled shafts and rock sockets in accordance with Sec 701. Sonic logging testing shall be performed on all drilled shafts and rock sockets.

The thickness of the steel casing shall meet all the requirements of Sec 701 with the minimum thickness being 1/2 inch.

Detailed Checked

Note: This drawing is not to scale. Follow dimensions.

Sheet No. of

DLS 01

IF A SEAL IS PRESENT ON THIS SHEET IT HAS BEEN ELECTRONICALLY SEALED AND DATED.